

P 標準ゲージ P Standard Gauges

P11 A型ゲージ P11 A type gauge

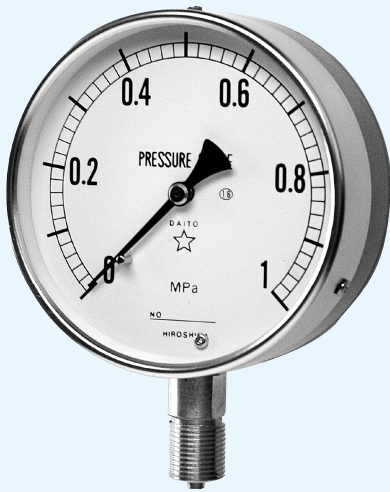

P11	ダイヤル径 Dial diameter	接続ネジ Connecting screw	圧力範囲(P.6) Pressure range (P. 6)	用途(P.6) Application (P. 6)
1	φ50	1: G1/4B	圧力範囲表より 選択して下さい。 Select from the pressure range table.	用途表より 選択して下さい。 Select from the application table.
2	φ60	2: G3/8B		
3	φ75	3: G1/2B		
4	φ100	4: R1/4		
5	φ150	5: R3/8		
6	φ200	6: R1/2		

上記ダイヤル径、接続ネジ以外のものについては、ご指定下さい。
(例: ダイヤル径 φ125、φ250、φ300、接続ネジ NPT、7/16フレア)
※ φ50は3/8・1/2、φ60は1/2製作不可

Specify any diameter and connecting screw other than the above dial diameters and connecting screws.
(Example: dial diameter φ125, φ250, φ300, connecting screw NPT, 7/16 flare)
* For φ50, connecting screws 3/8 and 1/2 are not available, and for φ60, connecting screws 1/2 are not available.

標準仕様 Standard specification	枠(外枠) Frame (Outer frame)	枠(内枠) Frame (Inner frame)	接続部 Connecting part	ブルドン管 Bourdon tube
φ50, φ60	SSクロームメッキ SS chrome plating	SSクロームメッキ SS chrome plating	C3604BD	低圧=C2680TW 高圧=C5191 工具鋼 SUS316
φ75以上 φ75 or larger	Al金色 Al gold	AC7A金色 AC7A gold	C3771BE	Low pressure = C2680TW High pressure = C5191 Tool steel SUS316

P 標準ゲージ 図面・寸法表 P Standard Gauge: Drawings & Dimensions Table

P11 A型ゲージ P11 A type gauge

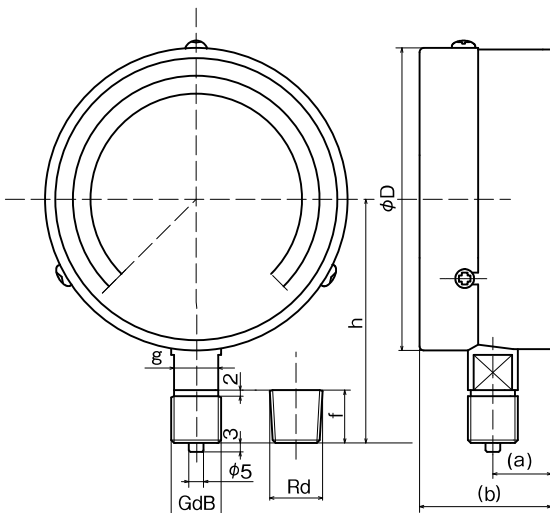

P11 A型 P11 A type

大きさ size	d	(a)	(b)	f	g	h	D
φ50	1/4"	10	28	14	14四角	46	52
φ60	1/4"	10	30	14(16)	14四角	56	63
φ75	1/4"	16	40	14	14二面取り	66	78
	3/8"			18		70	
φ100	3/8"	18	43	18	14二面取り	82	103
	1/2"			20		96	
φ150	3/8"	20	50	18	14二面取り	110	153
	1/2"			20		125	
φ200	3/8"	22	58	18	24六角	150	204
	1/2"			20		152	

14四角 = 14 Square 14二面取り = 14 Double D
24六角 = 24 Hexagon