

# P 標準ゲージ

## P Standard Gauges

### P13 D型ゲージ P13 D type gauge



P13	ダイヤル径 Dial diameter	接続ネジ Connecting screw	圧力範囲(P.6) Pressure range (P. 6)	用途(P.6) Application (P. 6)
	2: φ60	1: G1/4B	圧力範囲表より 選択して下さい。	用途表より 選択して下さい。
	3: φ75	2: G3/8B	Select from the pressure range table.	Select from the application table.
	4: φ100	3: G1/2B		
	6: φ150	4: R1/4		
	8: φ200	5: R3/8		
		6: R1/2		

上記ダイヤル径、接続ネジ以外のものについては、ご指定下さい。  
 (例: ダイヤル径 φ125、φ300、接続ネジ NPT、7/16フレア)  
 標準は前淵式(中間淵式の場合は、ご指定下さい。)  
 標準は三穴(金具付の場合は、ご指定下さい。)

※φ60は3/8、φ75は1/2製作不可 ※中間淵のφ200は製作不可

Specify any diameter and connecting screw other than the above dial diameters and connecting screws. (Example: dial diameter φ125, φ300, connecting screw NPT, 7/16 flare) Standard

gauges have a front flange (specify if an intermediate flange type is necessary). Standard gauges have 3 holes (specify if a gauge with fixture is necessary). \* For φ60, connecting screws 3/8 are not available, and for φ75, connecting screws 1/2 are not available. \* φ200 with an intermediate flange is not available.

標準仕様 Standard specification	枠(外枠) Frame (Outer frame)	枠(内枠) Frame (Inner frame)	接続部 Connecting part	ブルドン管 Bourdon tube
前淵式 Front flange type	SSクロームメッキ φ200→AC7A(白) SS chrome plating φ200 → AC7A (white)	SSクロームメッキ φ200→AC7A(白) SS chrome plating φ200 → AC7A (white)	C3604BD	低圧=C2680TW 高圧=C5191 工具鋼 SUS316
中間淵式 Intermediate flange type	Al金色 Al gold φ60→BsP	AC7A金色 AC7A gold	C3771BE	Low pressure = C2680TW High pressure = C5191 Tool steel SUS316

### P 標準ゲージ 図面・寸法表 P Standard Gauge: Drawings & Dimensions Table

#### P13 D型ゲージ P13 D type gauge

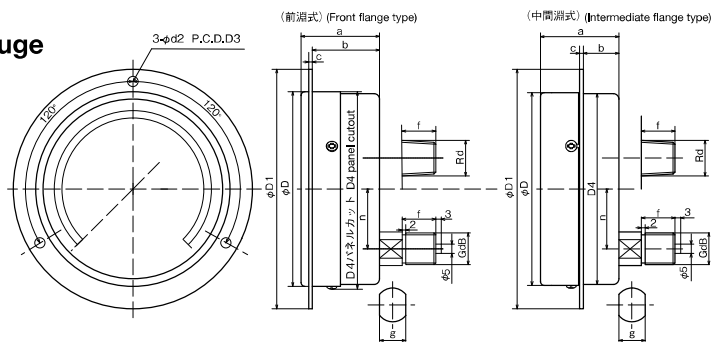

#### P13 D型 P13 D type

大きさ size	d	D	D1	d2	D3	D4(前淵) D4 (Front flange)	前a Front a	前b Front b	前c Front c	D4(中間) D4 (Intermediate)	中a Intermediate a	中b Intermediate b	中c Intermediate c	f	g	n
φ60	1/4"	63	80	4.5	72	67	31	23	1	63	33	14	2	14 (16)	12二面取り	20
φ75	1/4"	78	98	4.5	88	82	39	35	2	77	38	18	2.5	14	14二面取り	25
	3/8"													18		
φ100	3/8"	103	128	5.5	115	107	41	35	2	102	42	19	3	18	14二面取り	32
	1/2"													20		
φ150	3/8"	153	178	5.5	165	158	48	42	2	153	44	20	3	18	14二面取り	55
	1/2"													20		
φ200	3/8"	204	235	5.5	220	210	48	40	4	/	/	/	/	18	14二面取り	55
	1/2"													20		

12二面取り = 12 Double D 14二面取り = 14 Double D 24六角 = 24 Hexagon 19二面取り = 19 Double D