

M マイクロ接点 ゲージ (屋外用)

M Micro Contact Point Gauges (for Outdoors)

M13 D型ゲージ M13 D type gauge

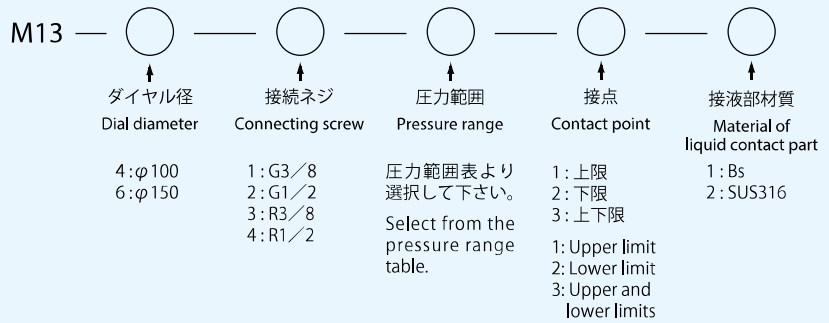

標準は金具付。※ $\phi 100$ は、2接点の屋外用は製作不可。

Standard gauges are equipped with fixtures. * For $\phi 100$, gauges with 2 contact points for outdoors is not available.

※ $\phi 150$ D型は、枠(内枠)が無くなり次第、B型へ移行します。

標準仕様 Standard specification

枠(外枠) Frame (Outer frame)	枠(内枠) Frame (Inner frame)	接続部 Connecting part	ブルドン管 Bourdon tube
AC7A黒塗 AC7A black coating	AC7A黒塗 AC7A black coating	C3771BD	C2680TW SUS316

M マイクロ接点 ゲージ (屋外用) 図面・寸法表 M Micro Contact Point Gauge (for Outdoors): Drawings & Dimensions Table

M13 D型ゲージ M13 D type gauge

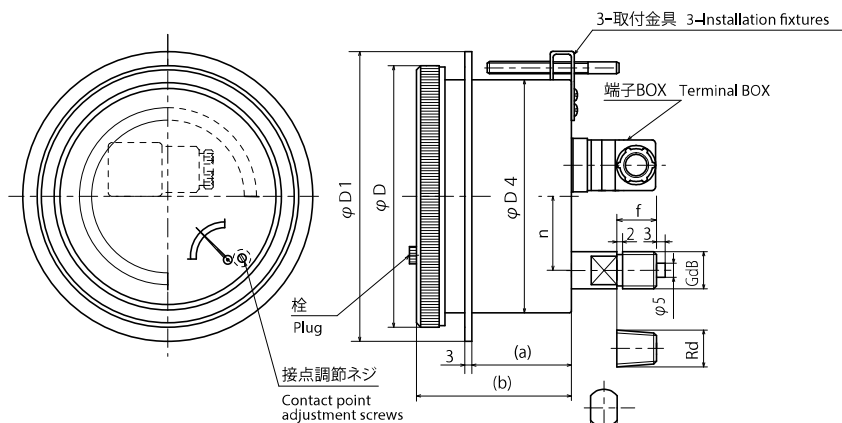

M13 D型 M13 D type

大きさ size	d	1接点 1 contact point		2接点 2 contact points		f	g	D4	n	D	D1
		(a)	(a)	(b)	(b)						
$\phi 100$	G3/8	57	78	18	14二面取り	105	32	120	128		
	R3/8										
	G1/2										
	R1/2										
$\phi 150$	3/8"	89	89	110	110	18	14二面取り	152	45	168	178
	1/2"										

14二面取り = 14 Double D
17二面取り = 17 Double D
1接点 = 1 contact point
2接点 = 2 contact points