

M マイクロ接点 ゲージ (屋外用)

M Micro Contact Point Gauges (for Outdoors)

M12 B型ゲージ M12 B type gauge

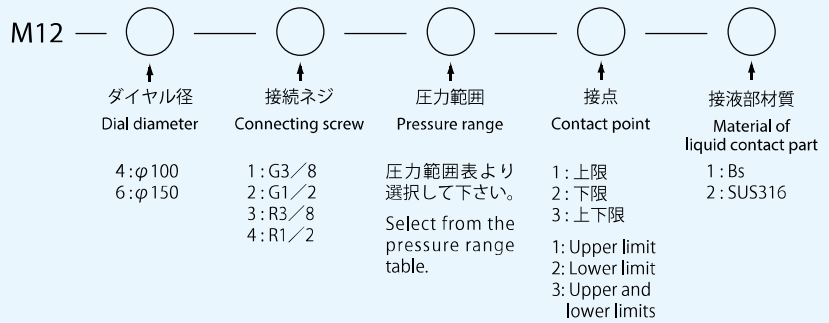

標準仕様 Standard specification

枠(外枠) Frame (Outer frame)	枠(内枠) Frame (Inner frame)	接続部 Connecting part	ブルドン管 Bourdon tube
AC7A黒塗 AC7A black coating	AC7A黒塗 AC7A black coating	C3771BD	C2680TW SUS316

M マイクロ接点 ゲージ (屋外用) 図面・寸法表 M Micro Contact Point Gauge (for Outdoors): Drawings & Dimensions Table

M12 B型ゲージ M12 B type gauge

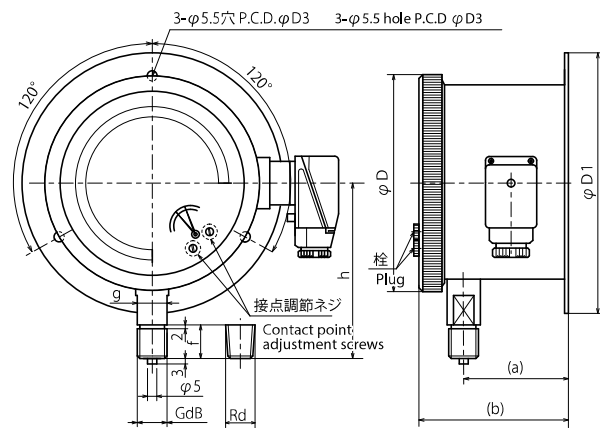

M12 B型 M12 B type

大きさ size	d	1接点 1 contact point		2接点 2 contact points		f	g	1接点 1 contact point		2接点 2 contact points		D	D1	D3
		(a)	(a)	(b)	(b)			h	h					
$\phi 100$	G3/8	53	77	79	105	18	17二面取り	94.5	94.5	115	128	115		
	R3/8							(94.5)	(94.5)					
	G1/2							92.5	92.5					
	R1/2							(96.5)	(96.5)					
$\phi 150$	3/8"	82	82	115	115	18	14二面取り	117	117	168	178	165		
	1/2"					20	17二面取り	119	119					

17二面取り = 17 Double D
14二面取り = 14 Double D
1接点 = 1 contact point
2接点 = 2 contact points
ただし () 内寸法はSUS製品です。
However, the dimensions
in the parentheses are for products made of SUS.