

A 赤針付ゲージ A Gauge with Red Pointers

A13 D型ゲージ A13 D type gauge

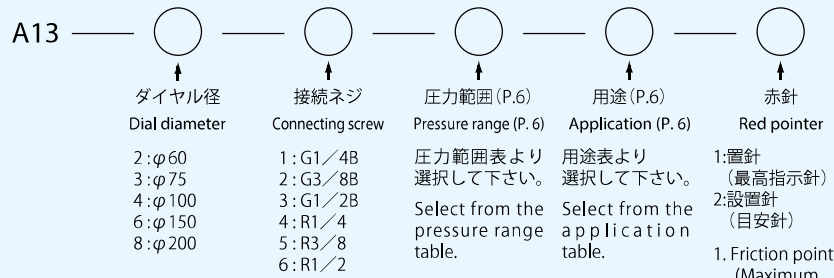

上記接続ネジ以外のものについては、ご指定下さい。

(例: NPT・7/16フレア-etc...)

標準は前淵式(中間淵式の場合は、ご指定下さい。)

標準は三穴(金具付の場合は、ご指定下さい。)

※φ60は3/8以上φ75は1/2以上製作不可 ※中間淵のφ200は製作不可

※置針は、外部振動の激しい場所のご利用は不向きです。

Specify connecting screws other than the above. (Example: NPT, 7/16 flare, etc.) Standard gauges have a front flange (specify if an intermediate flange type is necessary). Standard gauges have 3 holes (specify if a gauge with fixture is necessary). * For φ60, connecting screws 3/8 or larger are not available, and for φ75, connecting screws 1/2 or larger are not available. * φ200 with an intermediate flange is not available. * A friction pointer is not suitable for use in a place with severe external vibration.

標準仕様 Standard specification	枠(外枠) Frame (Outer frame)	枠(内枠) Frame (Inner frame)	接続部 Connecting part	ブルドン管 Bourdon tube
前淵式 Front flange type	SSクロームメッキ φ200→AC7A(白) SS chrome plating φ200 → AC7A (white)	SSクロームメッキ φ200→AC7A(白) SS chrome plating φ200 → AC7A (white)	C3604BD	低圧=C2680TW 高圧=C5191 工具鋼 SUS316
中間淵式 Intermediate flange type	Al金色 φ60→BsP Al gold φ60→BsP	AC7A金色 AC7A gold	C3771BE	Low pressure = C2680TW High pressure = C5191 Tool steel SUS316

A 赤針付ゲージ 図面・寸法表 A Gauge with Red Pointer: Drawings & Dimensions Table

A13 D型ゲージ A13 D type gauge

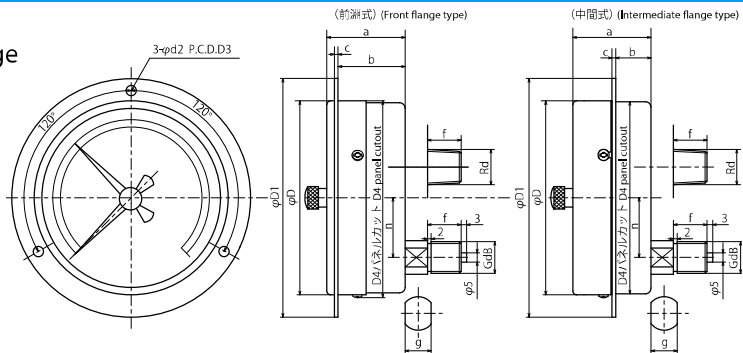

A13 D型 A13 D type

大きさ size	d	D	D1	d2	D3	D4(前淵) D4 (Front flange)	前a Front a	前b Front b	前c Front c	D4(中間) D4 (Intermediate)	中a Intermediate a	中b Intermediate b	中c Intermediate c	f	g	n
φ60	1/4"	63	80	4.5	72	67	31	23	1	63	33	14	2	14 (16)	12二面取り	20
φ75	1/4"	78	98	4.5	88	82	39	35	2	77	38	18	2.5	14	14二面取り	25
	3/8"													18		
φ100	3/8"	103	128	5.5	115	107	41	35	2	102	42	19	3	18	14二面取り	32
	1/2"													20		
φ150	3/8"	153	178	5.5	165	158	48	42	2	153	44	20	3	18	14二面取り	55
	1/2"													20		
φ200	3/8"	204	235	5.5	220	210	48	40	4	/	/	/	/	18	14二面取り	55
	1/2"													20		

12二面取り = 12 Double D 14二面取り = 14 Double D 24六角 = 24 Hexagon 19二面取り = 19 Double D