

WA 密閉ゲージ(金属) WA Enclosed Gauges (Metal)

WA12 B型ゲージ WA12 B type gauge

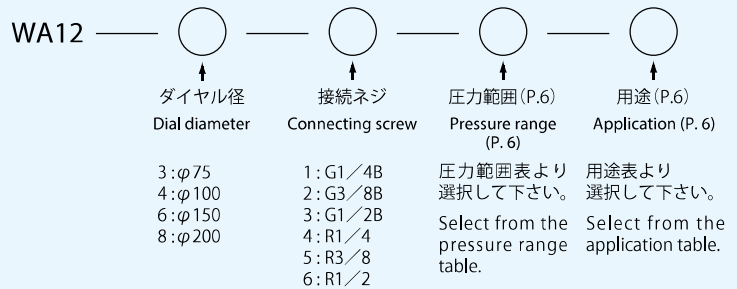
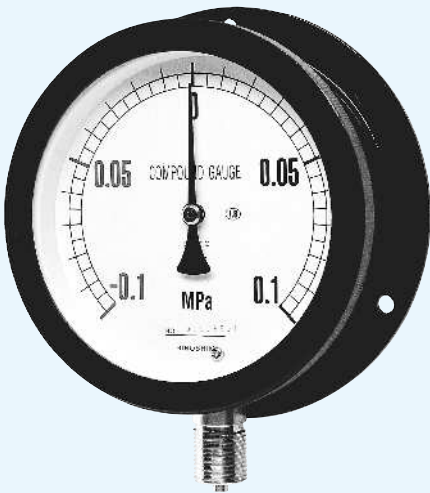

上記接続ネジ以外のものについては、ご指定下さい。(例: NPT・7/16フレア-etc...)

※φ75は1/2製作不可。 ※φ200はSUS・密閉製作不可。

Specify connecting screws other than the above. (Example: NPT, 7/16 flare, etc.)

* For φ75, connecting screws 1/2 are not available. * For φ200, SUS and enclosed gauges are not available.

標準仕様 Standard specification

枠(外枠) Frame (Outer frame)	枠(内枠) Frame (Inner frame)	接続部 Connecting part	ブルドン管 Bourdon tube
AC7A黒塗 AC7A black coating	AC7A黒塗 AC7A black coating	C3604BD C3771BE	低圧=C2680TW 高圧=C5191 工具鋼 SUS316 Low pressure = C2680TW High pressure = C5191 Tool steel SUS316

外枠・内枠をSUS304/接続部・ブルドン管をSUS316にされる場合は、ご指定下さい。※赤針(置針・設置針)が必要な場合は、ご指定下さい。

Specify if it is necessary to manufacture an outer frame and an inner frame with SUS304, and connecting parts and bourdon tubes with SUS316.

* Specify if a red pointer (friction pointer, index pointer) is necessary.

WA 密閉ゲージ(金属) 図面・寸法表 WA Enclosed Gauge (Metal): Drawings & Dimensions Table

WA12 B型ゲージ WA12 B type gauge

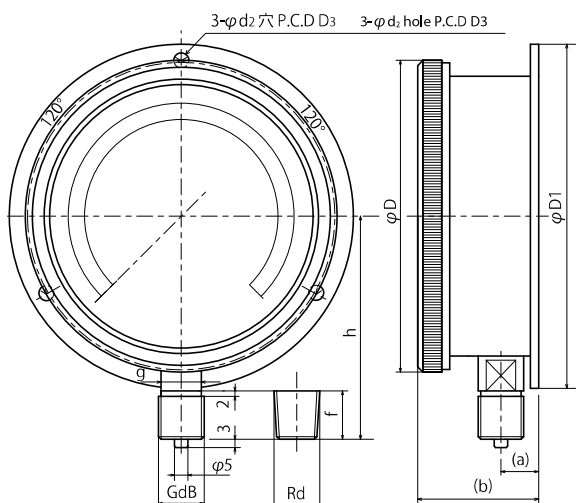

WA12 B型 WA12 B type

大きさ size	d	(a)	(b)	f	g	h	D	D1	D3	d2
φ75	1/4"	16	43	14	14二面取り	66	90	98	88	4.5
	3/8"			18		70				
φ100	3/8"	16	45	18	14二面取り	82	116	128	115	5.5
	1/2"			20		96				
φ150	3/8"	19	57	18	14二面取り	110	169	178	165	5.5
	1/2"			20		125				
φ200	3/8"	24	59	18	19二面取り	150	221	235	220	5.5
	1/2"			20		152				

14二面取り = 14 Double D 19二面取り = 19 Double D